

UF E200BMB Series

Black and Blue: High ; (Black or Blue) and Brown: Low
 Size : $\varnothing 250 \times 76.1$ Unit : mm

(EC Fan)

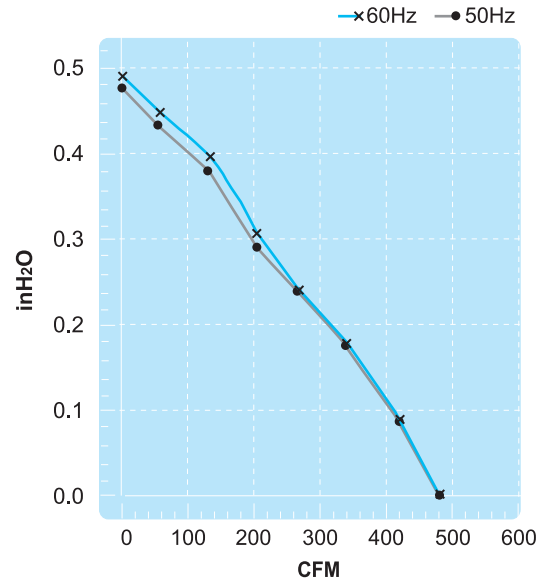
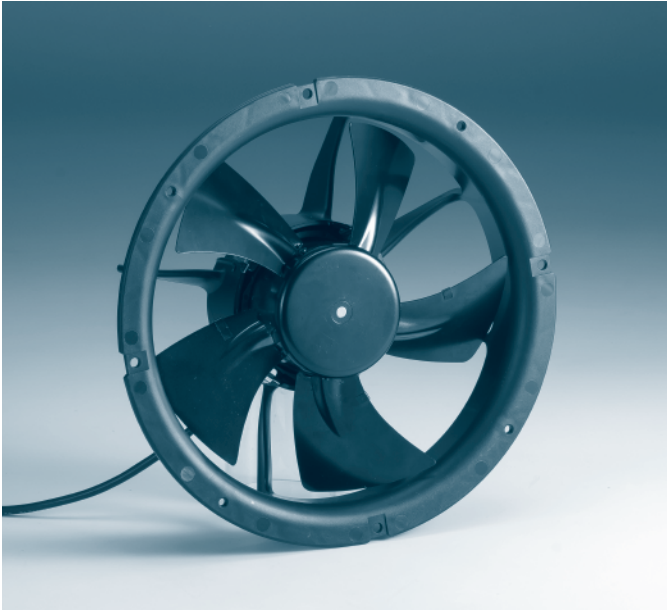

Thermally-Protected

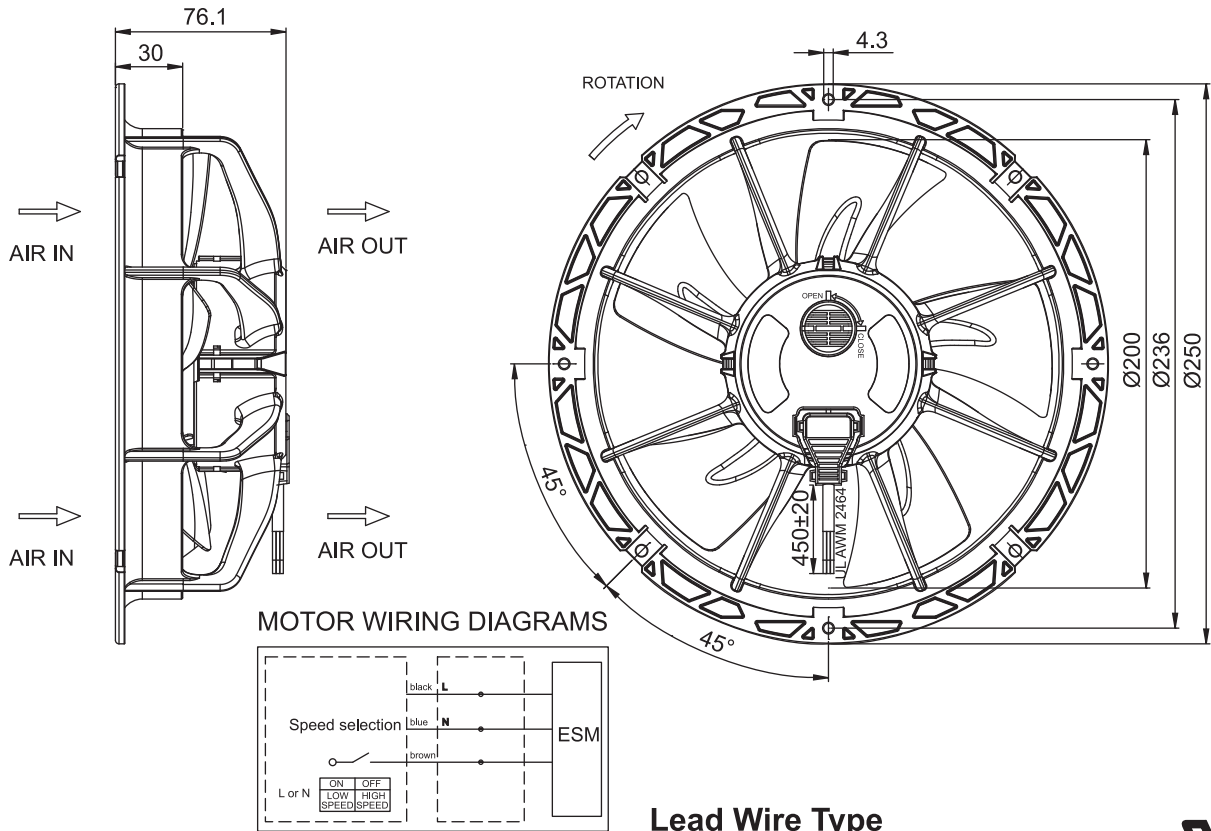

Lead Wire Type



Spec.	Rated Voltage V	Frequency Hz	Input Power W	Rated Current A	Speed RPM	Maximum Air Flow m ³ /min.	Maximum Air Flow CFM	Maximum Pressure mmH ₂ O	Maximum Pressure InchH ₂ O	Noise dB	Weight kg
Model											
UFE200BMB11H1D4A	115V	50 / 60	26 8	0.40 0.11	2200 1400	13.5 8.4	477 296	12 7	0.47 0.28	55 44	1
UFE200BMB23H1D4A	230V	50 / 60	26 8	0.23 0.07	2200 1400	13.5 8.4	477 296	12 7	0.47 0.28	55 44	1