

ACCESSORIES

Fan Guard

Unit: mm

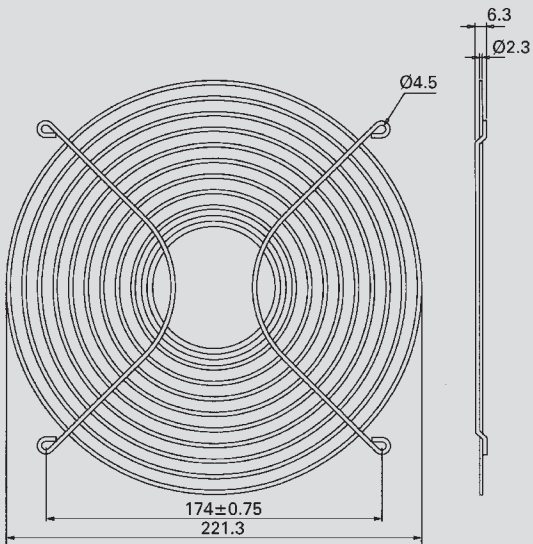
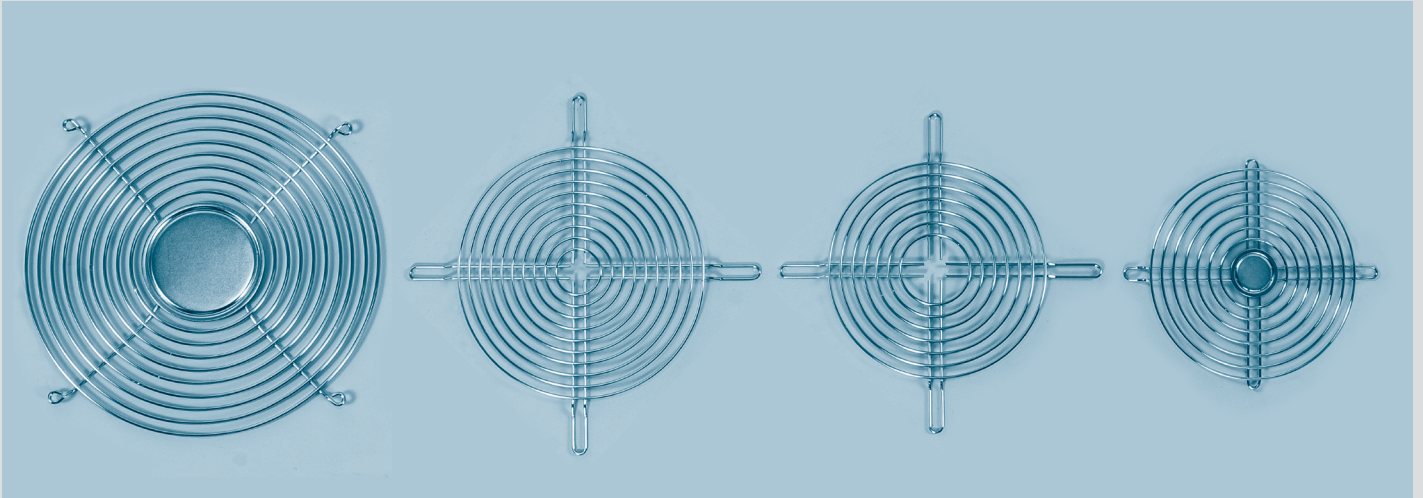

MG-25 (For UF25HC, 25GC, 25GCA, 25GCB, 20JC Series)
*Steel

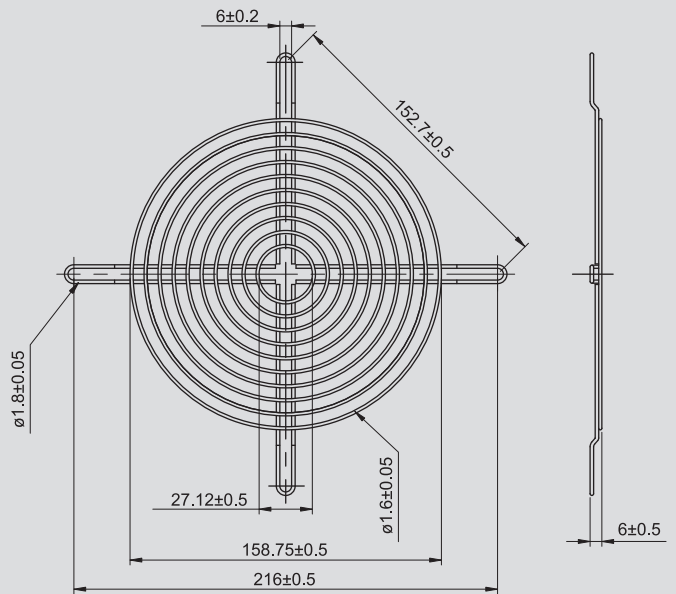

MG-18 (For UF18JC Series)
*Steel

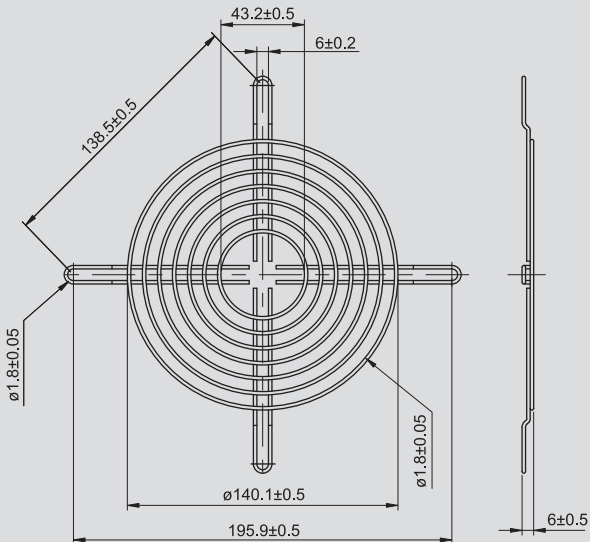

MG-16 (For UF16FC Series)
*Steel

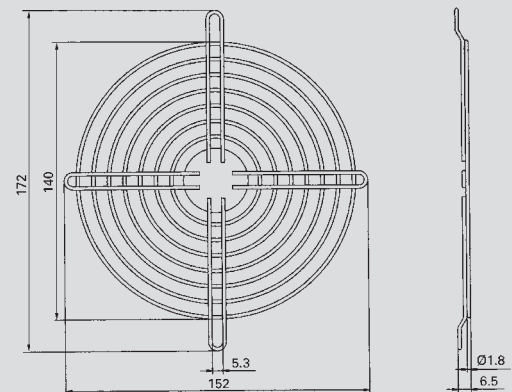

MG-15 (For UF15P, 17P, 15PC, 15KC, 17PC, 15AC Series)
*Steel

* Dimensions of fan guards are only for reference, for details please send your inquiry.